

# GOT5100T-832

10.4" SVGA TFT Fanless Touch Panel  
Computer with Intel® Atom™ Processor  
N2600

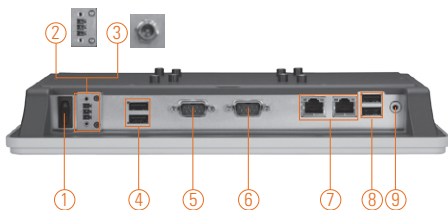

- |   |                     |
|---|---------------------|
| 1. Power switch   | 6. COM 2 (RS-232)   |
| 2. Terminal block for DC power input<br>or 3. Screw conn. w/ AC power adapter | 7. Ethernet x 2     |
| 4. USB 2.0 x 2  | 8. USB 2.0 x 2      |
| 5. COM 1 (RS-232/422/485)   | 9. Audio (Line-out) |



## Introduction

The GOT5100T-832 is a 10.4" Intel® Atom™-based fanless touch panel computer. In response to market demand, this panel computer is a cost effective solution. It adopts a modern, super sleek and fanless design and is equipped with a 10.4" TFT LCD as well as Intel® Atom™ processor N2600 1.6 GHz. For wireless network connection, the GOT5100T-832 offers a PCIe Mini Card slot. By just plugging in the mini card WLAN card, customers can have instant access to wireless LAN/GPRS/GSM/4G environments. Besides, it provides two types of power input. One is DC power input (10~30VDC) with terminal block connector, and another is AC power adapter with screw type connector.

### Super slim & ultra lightweight design

The GOT5100T-832 is a super slim touch panel computer for space-limited environment with its thickness of 45.8 mm and weight of 1.8 kg only, which make it installed everywhere.

### Built-in internal WLAN antenna

The GOT5100T-832 provides a PCIe Mini Card slot and a built-in WLAN antenna for wireless network connections. By simply plugging in the wireless LAN card, customers can use the GOT5100T-832 in a wireless LAN/GPRS/GSM /4G environments.

### Excellent thermal solution: aluminum back chassis

With Axiomtek's patent for plastic plus aluminum mechanism design, the GOT5100T-832 can dissipate the heat easily and keep the system operation stable

## Features

- 10.4" SVGA TFT LCD display with LED backlight
- Fanless design with Intel® Atom™ processor N2600 2 cores @1.6 GHz
- Supports WLAN module & internal antenna
- Supports 2 Gigabit LAN, 4 USB 2.0 & 2 COM ports
- Supports optional panel mount, wall mount, VESA arm and desktop stand
- Plastic and IP65-rated front bezel
- Supports RFID (optional)



▲ Side view



▲ Desktop stand

## Specifications

Front Bezel	IP65, NEMA 4 rugged protection, plastic front bezel		
LCD Panel	Display Type	10.4" SVGA TFT LCD	
	Brightness (cd/m <sup>2</sup> )	400 nits	
	Resolution	800 x 600	
	Viewing Angel (H/V)	140°/120°	
Main System	CPU	Intel® Atom™ processor N2600 2 cores @1.6 GHz	
	Chipset	Intel® NM10 Express	
	System Memory	1 x 204-pin DDR3 800/1066 MHz SO-DIMM up to 2 GB	
	BIOS	AMI UEFI BIOS	
	Storage	1 x 2.5" SATA HDD 1 x CompactFlash™	
		Watchdog Timer	255 levels, 0~255 sec.
	Onboard Graphics	Integrated in Intel® GFX	

\* All specifications and photos are subject to change without notice.



## Specifications

I/O Connector	1 x RS-232/422/485 (default RS-232, COM 1) 1 x RS-232 (COM 2) 2 x 10/100/1000Mbps Ethernet 4 x USB 2.0 1 x Audio (Line-out)
Expansion Interface	1 x PCIe Mini Card
Touchscreen	Resistive type
Power Supply	1. DC version: 10-30VDC with over-current protection fuse 2. AC version: 100-240V AC-DC 60W power adapter
Dimension	292.5 mm (11.52") (W) x 45.8 mm (1.80") (D) x 235.8 mm (9.28") (H)
Packing Dimensions	415 mm (16.34") (W) x 100 mm (3.94") (D) x 315 mm (12.4") (H)
Weight (net/gross)	1.8 kg (3.96 lb)/3 kg (6.61 lb)
Environment	Operating temperature: 0° ~ +50°C (+32°F ~ +122°F) (with W.T. DRAM/HDD in airflow condition) 0° ~ +45°C (+32°F ~ +113°F) (with W.T. DRAM/HDD) Storage Temperature: 0° ~ +50°C (+32°F ~ +122°F) (in airflow condition) Relative humidity: 20% ~ 90% @ 40°C; non-condensing Operation vibration: 2G, 5-500Hz, random for CompactFlash™
Certificate	UL60950-1, CE

## Ordering Information

GOT5100T-832-J	8.4" SVGA fanless touch panel computer with Intel® Atom™ processor N2600, 5-wire resistive touch screen AC-DC 60W power adapter (screw type connector) and EMI class B
GOT5100T-832-DC	8.4" SVGA fanless touch panel computer with Intel® Atom™ processor N2600, 5-wire resistive touch screen and 10-30VDC power input (terminal block connector)

\* Specification and certifications are based on options and may vary.

## Optional EOS Installation

WES  
WES 7

## Optional OS Installation

Windows® XP  
Windows® 7



## Dimensions

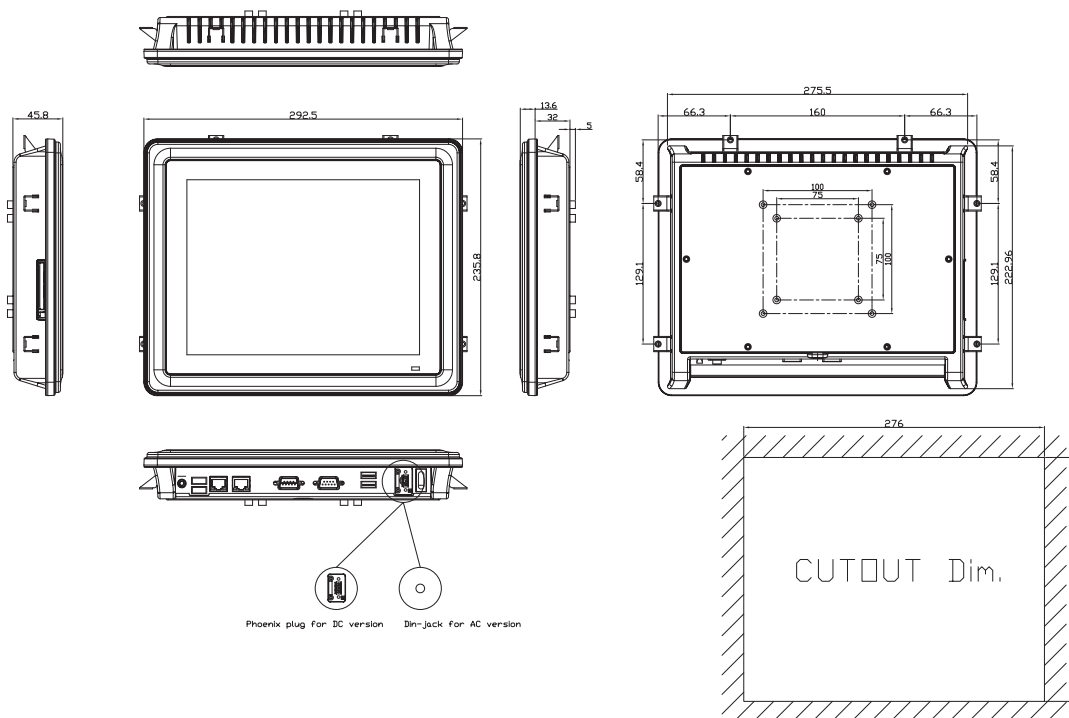

Overview

1 Fanless Touch Panel Computers

Heavy-duty Fanless Touch Panel Computers

Industrial Touch Panel Computers

Industrial Touch panel Monitors

Infotainment Touch Panel Computers

Healthcare & Medical Solutions

Open Frame Panel Computers

Accessories

